



Yúusnewás

St. Paul's Indian Residential School
Student Experience Project

For more information about Yúusnewás, please visit the Squamish Nation website squamish.net or email Yuusnewas@squamish.net

Community Collaboration

Community teams are answering questions,
national collaboration changes the future
conversation for all.



Problem Statement

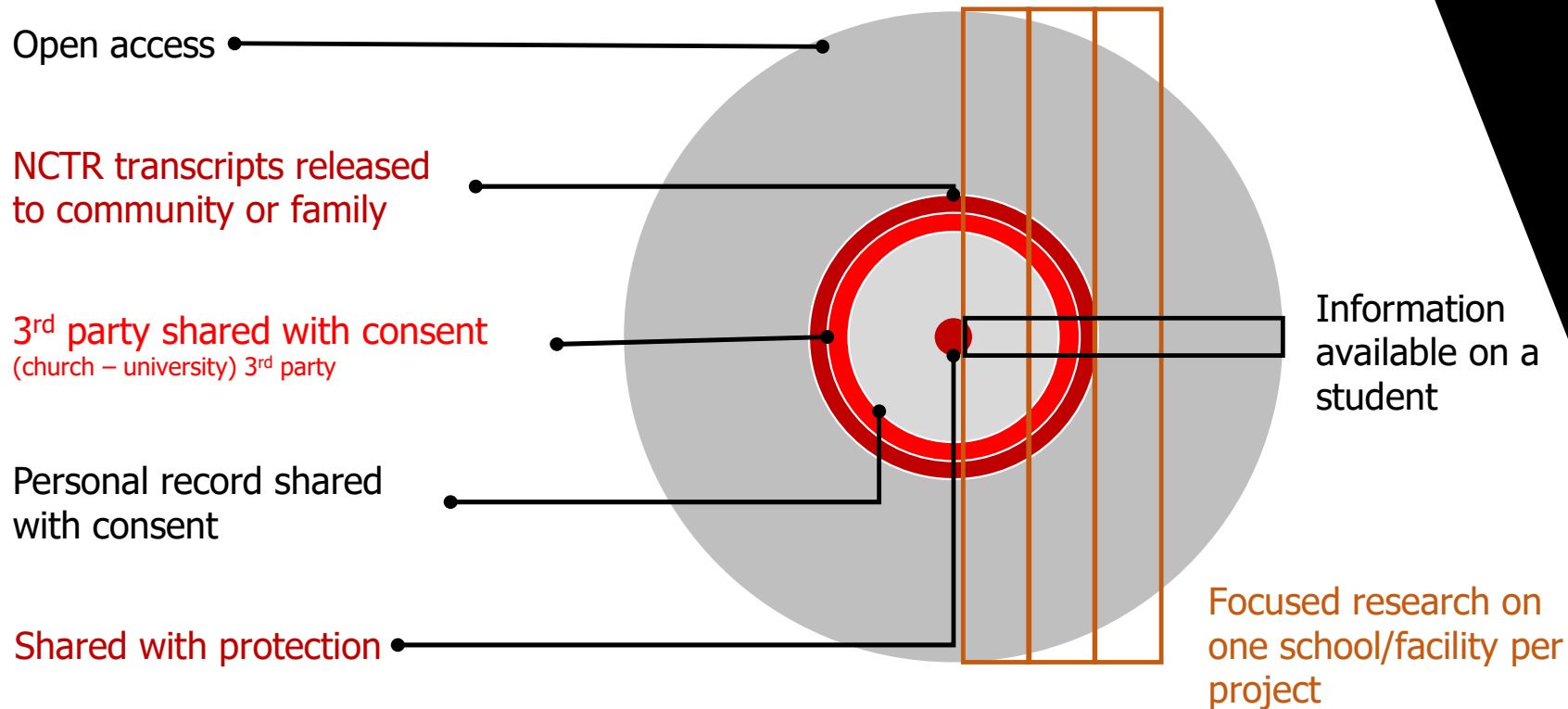

Public Information

Communities may be unaware of the schools and hospitals their community members attended. Public data is only a partial view into the history.

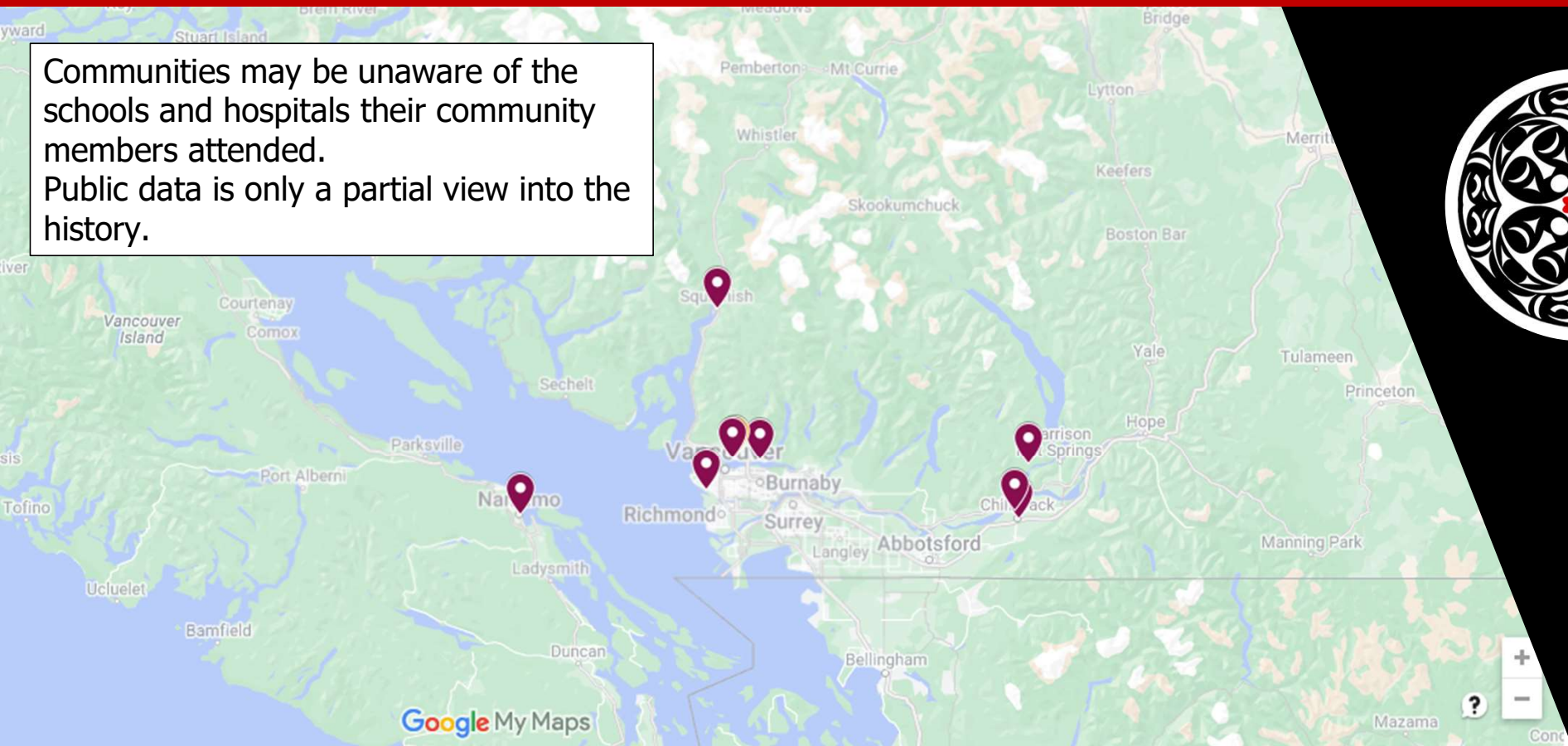

Protected Information

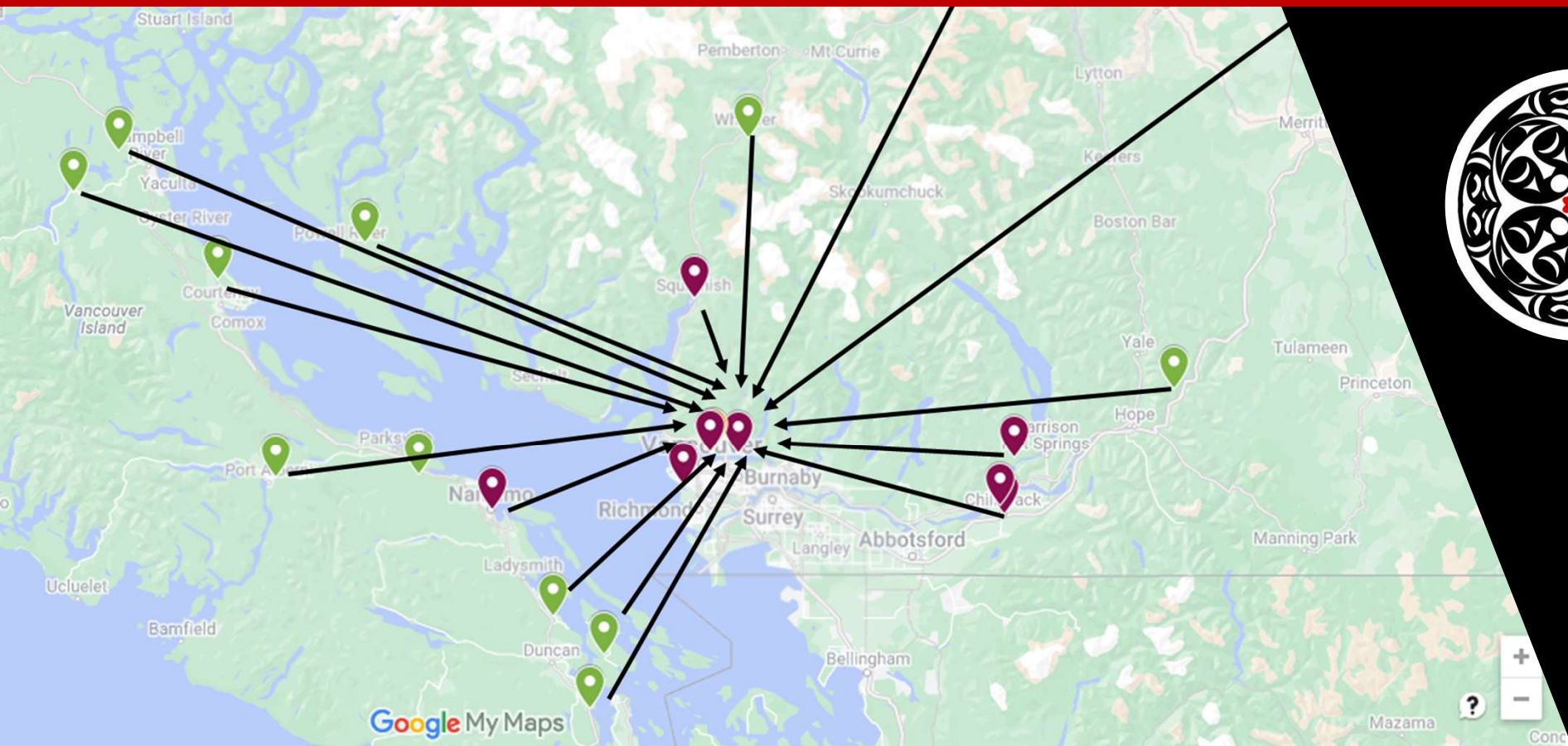

Public Records for Squamish Students

Every community will have their own map, which shows the distance facilities children went to school. Example: Squamish children went to 8 other schools other than St. Paul's in the public records.



Solution

MOUs and data sharing agreements across communities.

Seamless access to the most up to date information via a shared Indigenous platform.



MOU

Lead communities

- Have access to public and restricted data and archives for specific facilities
- Have rights to make decisions on how to research on behalf of all students who are associated with facility

Neighbouring communities

- Have rights to community specific data and archives
- Have data and archives that are critical to the student experience



MOU

Confidentiality and Privacy

- Data cannot be used for any purpose other than project and community research
- Protected data is not for any public release or public reporting such as a story or book
- Agreement that release of information could harm survivors and families, and is not something that can be repaired legally



Indigenous Analytic Platform

National Indigenous Archives – NIArchives.ca

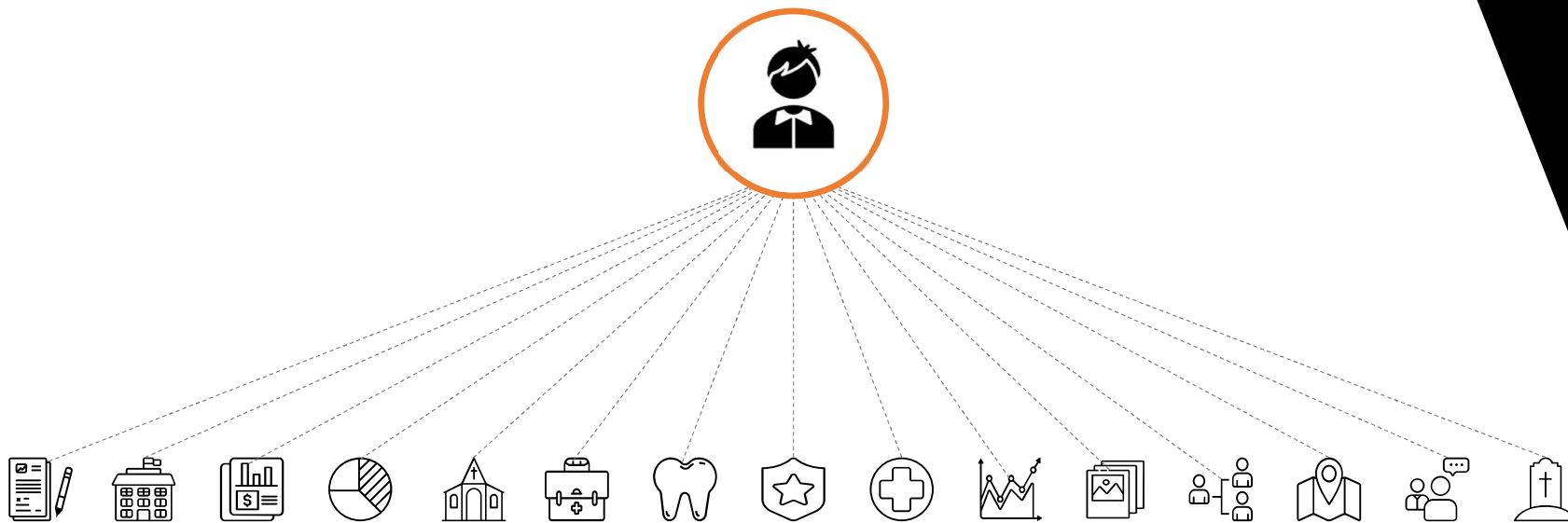



LOG IN

or use [login page](#)

US English ▾

v 4.1.1.1

No case defined

- Workspace
- Universe Viewer
- Link chart
- Folder
- Search

Testing installation
License will expire in 27877 days
NON-PRODUCTION ENVIRONMENT

- App monitoring
- Notifications
- Exports
- Ashley Whitworth

- Open
- Save analysis
- Reset
- Layout
- Create connection
- Create set

Find set/column

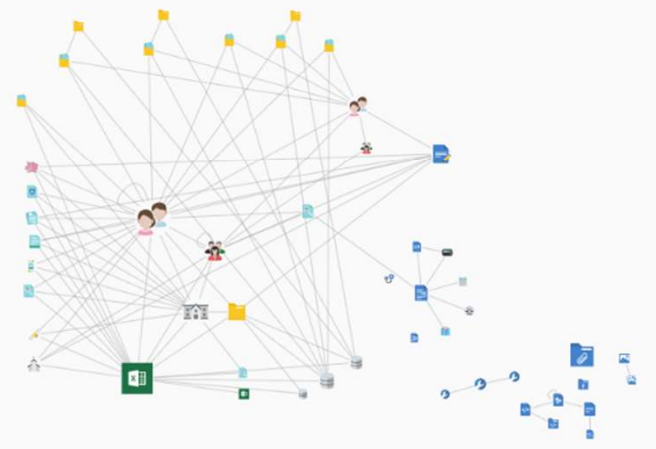

- Zoom in (+)
- Zoom out (-)

- Home
- Eye
- Bar chart

DataWalk

CASE

No case defined

- Workspace
- Universe Viewer
- Link chart
- Folder
- Search

Testing installation
License will expire in 27877 days

NON-PRODUCTION ENVIRONMENT

- App monitoring
- Notifications
- Exports
- Ashley Whitworth

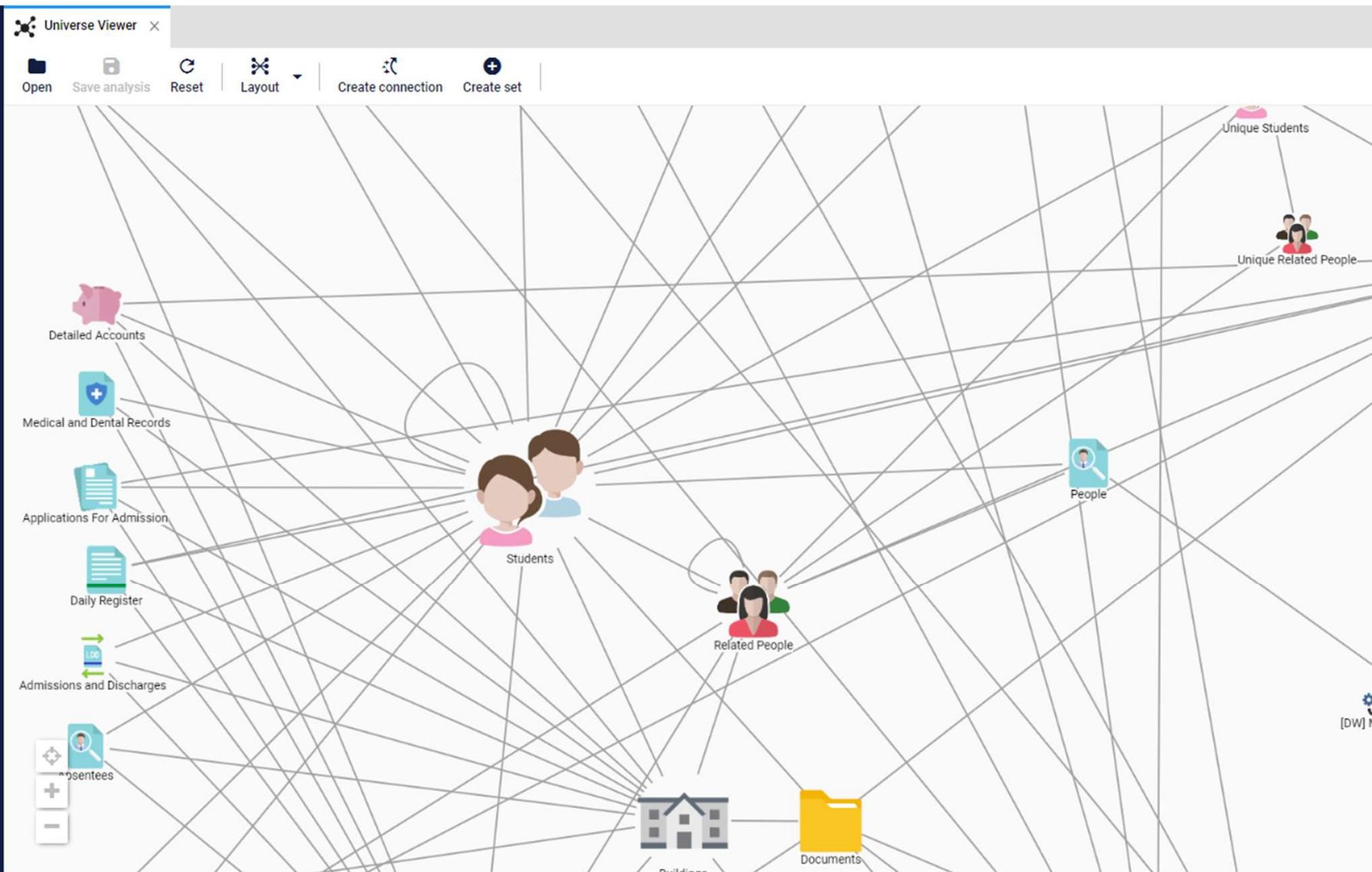

DataWalk

CASE

No case defined

Workspace

Universe Viewer

Link chart

Folder

Search

Testing installation
License will expire in 27875 days

NON-PRODUCTION ENVIRONMENT

App monitoring

Notifications

Exports

Genevieve Wick

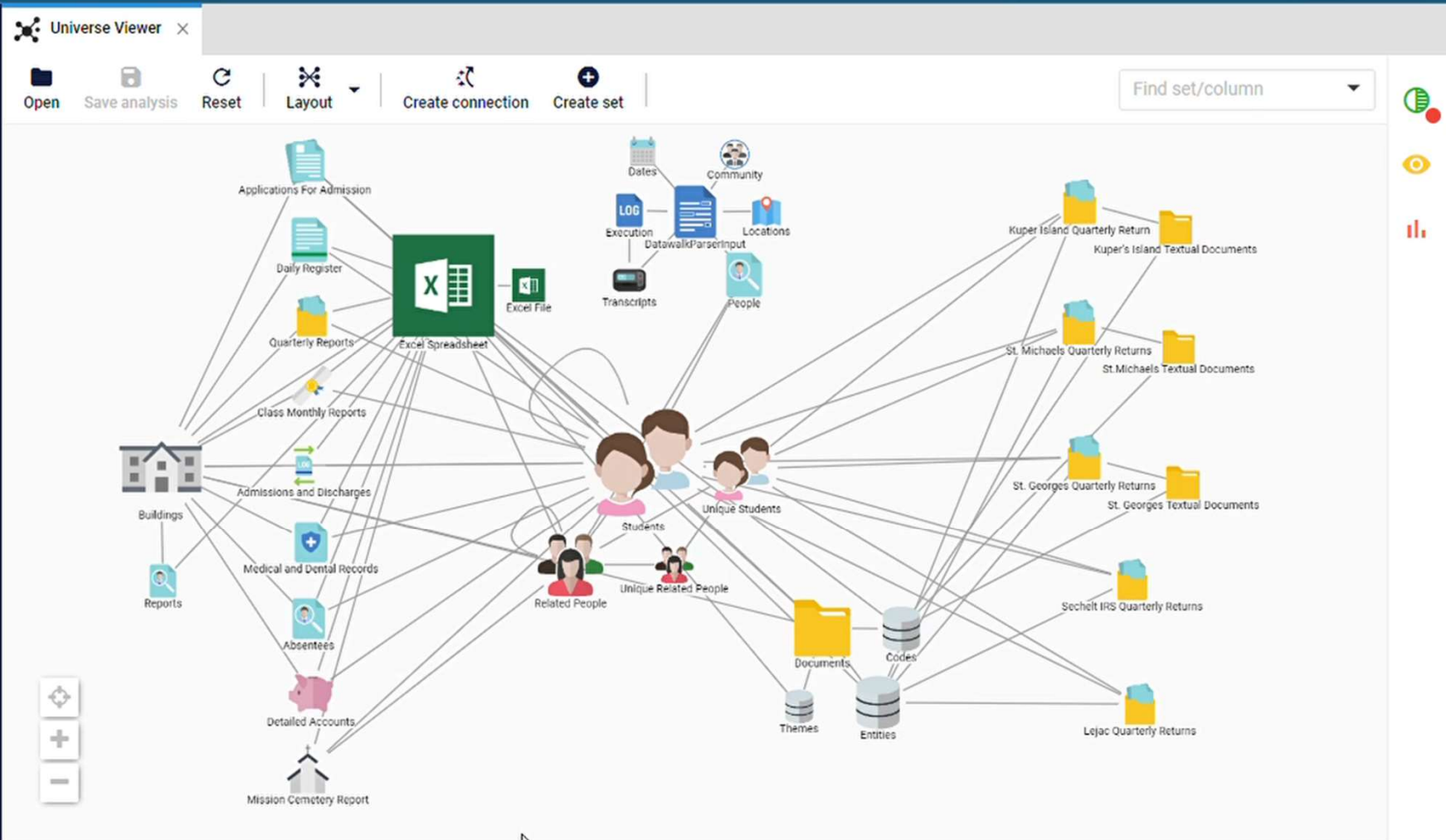

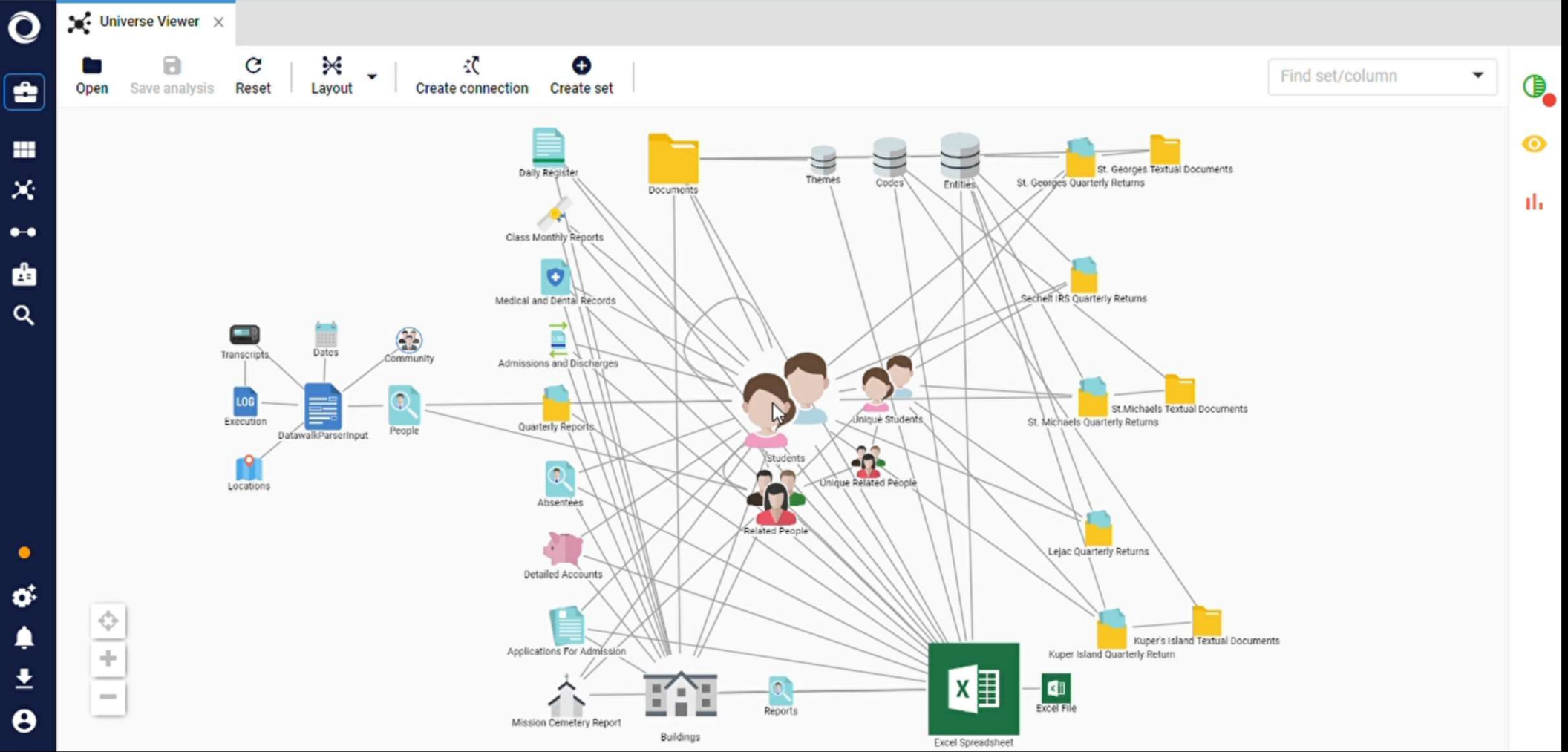

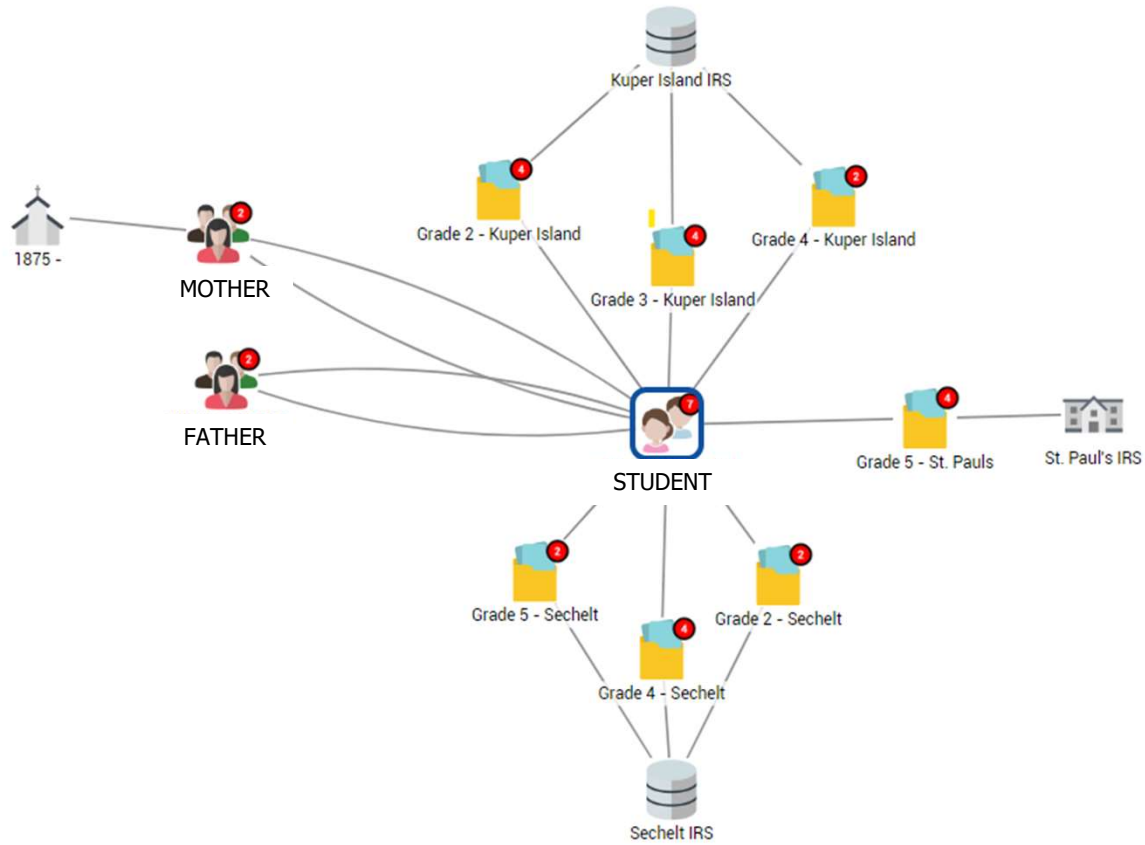

Using a small amount of data, we can already see connections to parents, schools, and experiences with only a few clicks.

Questions and Discussion

Ashley Whitworth – Project Director
for the Yúusnewas Project

1.250.744.8243 (text / phone)

Please reach out during this conference
to chat or let's connect after.



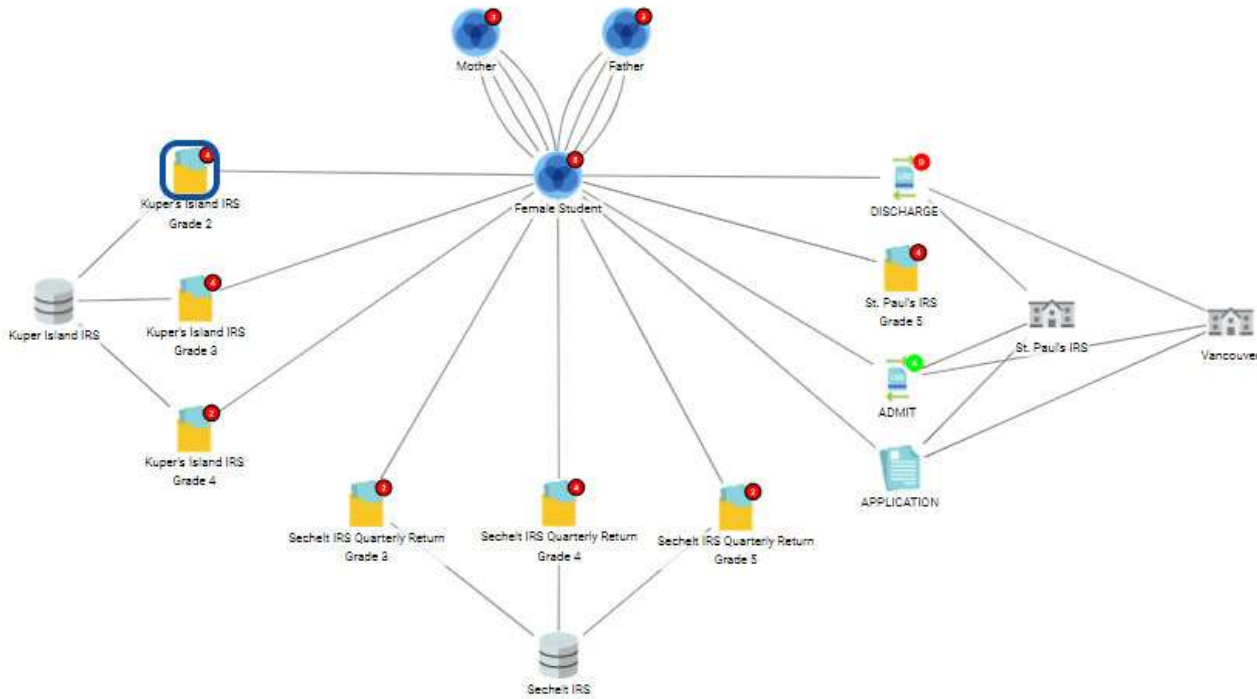

Object view x

- Kuper's Island IRS Gra... (...)
- Kuper's Island IRS Grade 2

.pdf filename KupIs_QR_Dec46.pdf

AdmitDate 09/01/1946

Age 10

Assessment Very Good

City Cowichan

City2 Penelakut

Course Sew

DW Source ... 4,890,010

DW Source ... 14

Date of Birth

DaysInClass 30

DaysInRes 92

First

Fiscal 46/47

Full Name

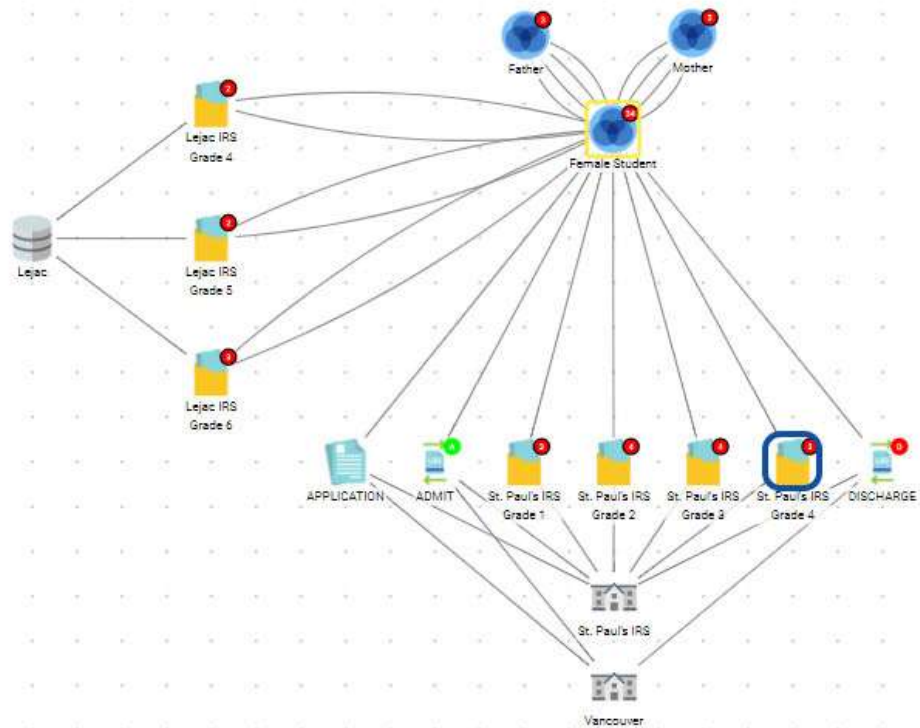

Object view

Assessment	Fair
City	North Vancouver
Course	Domestic Science
Days In Cla...	25
Days In Res	31
Display (Re...	-81276480000 Domestic ...
File Name	
Fiscal	43/44
Grade	4
Hospital	
Page #	
Quarter	Q3
Remarks	Transferred to Lejac Resid...
Report Date	3/31/1944
Research N...	
Seq	902
Sick In	
Sick Out	

Quarterly Reports
Filters on Quarterly Reports
Hospital = Y

Quarterly Returns filtered to show instances of hospitalization

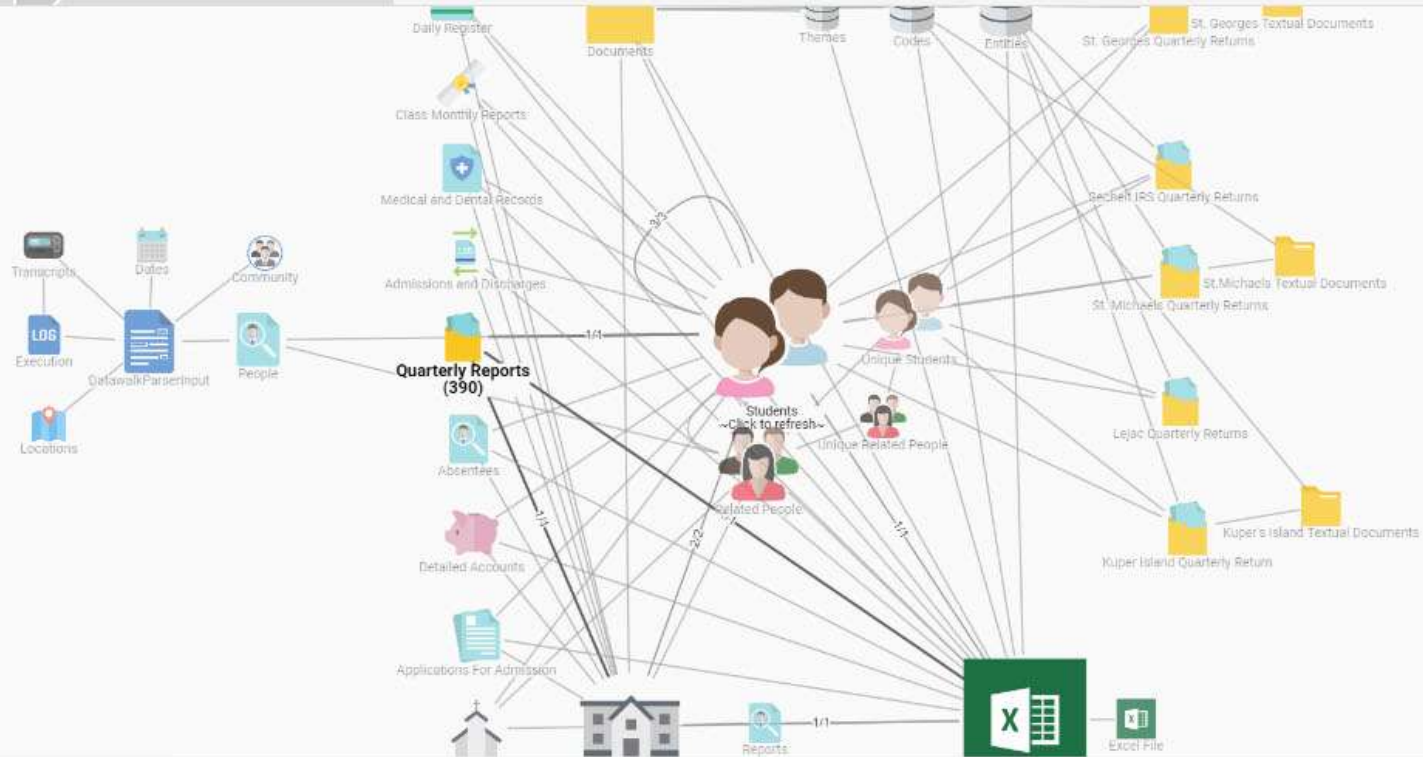

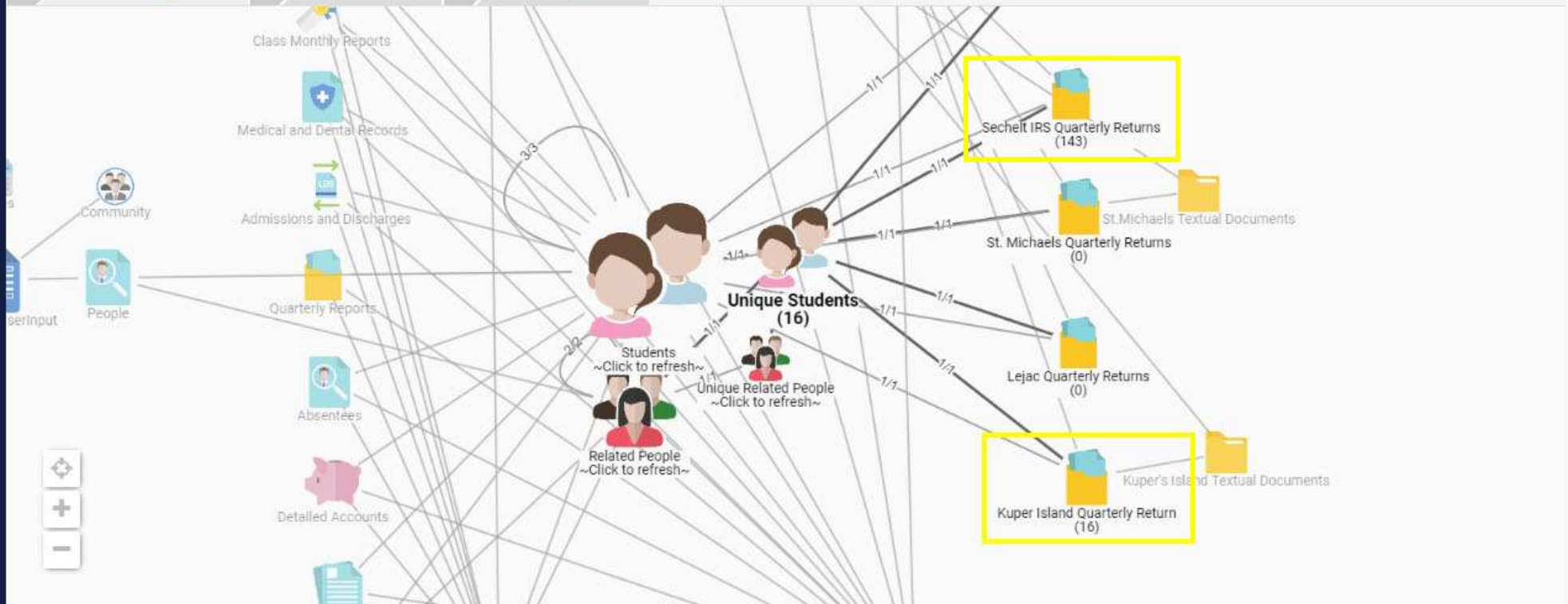

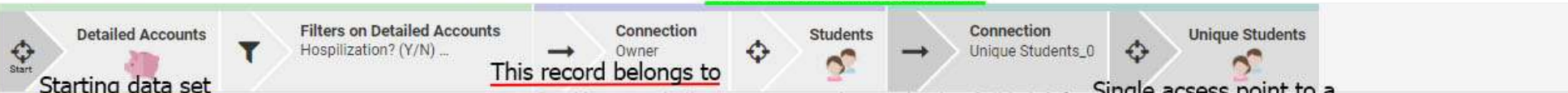

Each instance of a student

Single access point to a compilation of a Students records

